

# PMC-D961MD DC Multifunction Meter



The PMC-D961MD DC Multifunction Meter is CET's latest offer for the low-cost DC metering market. Housed in an industry standard DIN form factor measuring 96x96x92mm, it is perfectly suited for industrial, commercial and utility DC metering applications. The PMC-D961MD complies with Class 0.5 kWh Accuracy and features quality construction, multifunction measurements and a bright, easy to read LCD display. The PMC-D961MD comes standard with two Front Panel LED indicators for Energy Pulsing and Communication. It provides 4xDI for status monitoring, 2xDO for Control and Alarming, and 1xSS Pulse Output for kWh Energy Pulsing applications. The standard SOE Log records meter events such as power-off, Setpoints, setup changes and DI operations in  $\pm 1$ ms resolution. With a standard RS-485 port and an optional 10Base-T/100Base-TX Ethernet Port support, the PMC-D961MD becomes a vital component of an intelligent, multifunction monitoring solution for any DC Power and Energy Management systems.

## Typical Applications

- DC Inverter, DC Panel Metering and DC Charging Station
- Industrial and commercial DC metering
- DC Distribution Monitoring

## Features Summary

### Ease of use

- Large, 7-Segment LCD display
- Intuitive user interface
- LED indicators for Energy Pulsing and Communication activities
- Password protected setup via Front Panel or free setup software
- Easy installation with mounting clips, no tools required

### Measurements

- Voltage, Bi-directional Current and P Import/Export
- Bi-directional kWh measurements, kWh Net & Total

### Demands

- Present Demands for Current and P
- Max. Demands with Timestamp for This Month & Last Month

### Setpoints

- 6 user programmable Setpoints with extensive list of monitoring parameters including Voltage, Current, Power and P Demand, etc.
- Configurable thresholds, time delays and DO triggers

### SOE Log

- 32 events time-stamped to  $\pm 1$ ms resolution
- Setup changes, Power On/Off, Setpoints and DI status changes as well as DO operations

### Max./Min. Log

- Max./Min. Log with Timestamp for Current and P
- Configurable for This Month/Last Month

### Monthly Freeze Log

- Monthly Log with Timestamps for kWh Import/Export
- Available through Modbus communication for 24 Monthly Freeze records

### Inputs and Outputs

- 2x Front Panel LED indicator for Energy Pulsing and Communication
- 4xDigital Input for Status Monitoring
- 2xDigital Output for Control and Alarming
- 1xSS Pulse Output

## Communications

- Standard with one RS-485 port with baud rate from 1.2kbps to 38.4kbps
- One optional 10Base-T/100Base-TX Ethernet Port with RJ45 connector
- Modbus RTU and Modbus TCP support

## Real-Time Clock

- Battery-backed Real-time Clock with 6ppm accuracy ( $\leq 0.5$ s per day)

## System Integration

- Supported by our PecStar® iEMS
- Easy integration into other Automation, SCADA or BMS systems via Modbus RTU

## Accuracy

Parameters	Accuracy	Resolution
Voltage	$\pm 0.2\%$	0.001V
Current	$\pm 0.5\%$	0.001A
P	$\pm 0.5\%$	0.001W
kWh	Class 0.5	0.1kWh

## Technical Specifications

DC Inputs	
<b>Voltage Input</b>	
Standard (Un)	1000V DC
Measurement Range	10-1500V DC
Overload	1.5xUn continuous
<b>Current Input</b>	
Nominal Input (In)	$\pm 4$ V or $\pm 5$ V (via Hall-Effect Sensor)
Measurement Range	0.8% to 120% In
Burden	<0.001 VA
Overload	1.2xIn continuous
Power Supply (L/+, N/-)	
Standard	24-250 VAC/DC, $\pm 10\%$ , 47-440Hz
Burden	<2VA
Digital Inputs (DIC, DI1, DI2, DI3, DI4)	
Type	Dry contact, 24VDC internally wetted
Hysteresis	20ms minimum
Digital Outputs (DO11, DO12, DO21, DO22)	
Type	Form A Mechanical Relay
Loading	5A @ 250VAC or 30VDC
Pulse Output (E+, E-)	
Type	Solid-State Pulse Output
Pulse Constant	1/10/100/400 Imp/kWh
Pulse Width	80ms $\pm$ 20ms
Communications	
<b>RS-485 Port</b>	
Baud Rate	1200/2400/4800/9600/19200/38400bps
Protocol	Modbus RTU
<b>Ethernet Port (Optional)</b>	
Speed	10/100 Mbps
Protocol	Modbus TCP
Environmental Conditions	
Operating Temp.	-25°C to 70°C
Storage Temp.	-40°C to 85°C
Humidity	5% to 95% non-condensing
Atmospheric Pressure	70 kPa to 106 kPa
Mechanical Characteristics	
Panel Cutout	92x92 mm
Unit Dimensions	96x96x92 mm
IP Rating	IP65

Designed For Reliability

Manufactured To Last

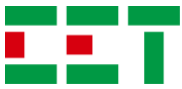

# PMC-D961MD DC Multifunction Meter

## Rear Panel

1	1x RS-485
2	4x Digital Input
3	1x Solid State Pulse Input
4	Power Supply
5	Ethernet Port (Optional)
6	2x Digital Output
7	Voltage Input
8	Hall Sensor Power Supply
9	Hall Sensor Current Input

## Installation and Dimensions

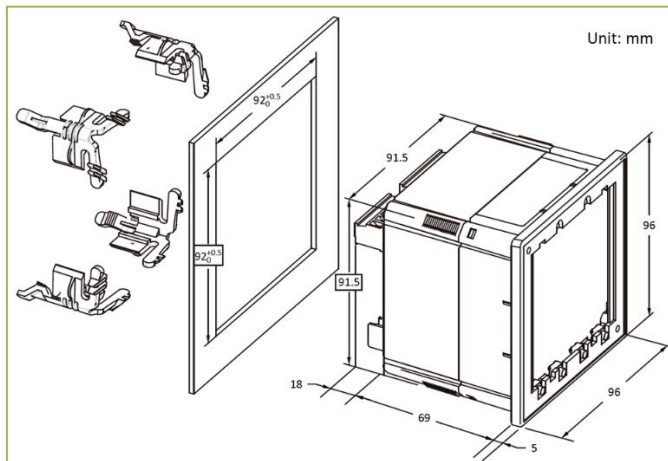

## Ordering Information

**CET** Version 20251015

Product Code	Description
PMC-D961MD	DC Multifunction Meter
<b>Basic Function</b>	
L	DIN96 Panel Mounting, 7-Segment LCD display, 1xDC Voltage Input, 1xDC Current Input and Bi-directional kWh measurements, Demands, Max./Min. Logs, Monthly Freeze Logs, Setpoints and SOE Logs
<b>Input Current</b>	
2	1 x ±4V/5V DC Input via Hall-Effect Sensor
<b>Input Voltage</b>	
5	10-1500V DC
<b>Power Supply</b>	
2	24-250 VAC/DC ± 10%, 47-440Hz
<b>I/O</b>	
A	4xDI + 2xDO + 1xPulse Output
<b>Communications</b>	
A	1xRS-485 Port
E*	1xRS-485 Port + 1x10Base-T/100Base-TX Ethernet Port
<b>Display Language</b>	
E	English
PMC-D961MD - L 2 5 2 A A E	PMC-D961MD-L252AAE (Standard Model)

\*Additional charges apply.  
 1) Please refer to Accessories sheet for Hall-Effect sensors' order information.  
 2) ±12V DC Power supply required for Hall-Effect Sensors will be supplied by PMC-D961MD device. No additional power supply is required.

**CET** Version 20251015

PMC-D961MD Accessories						
Split-Core Hall-Effect Sensor						
Product Code	Model #	Specification	Accuracy	Dimension (mm)	Burden (W)	Cable Length
180005732	PMC-DCT-200A-4V-A	200(300)A	Class 1	Round hole, φ35	0.3	Not included
180005733	PMC-DCT-400A-4V-A	400(600)A	Class 1	Square hole, 42x15	0.3	Not included
180005734	PMC-DCT-600A-4V-A	600(900)A	Class 1	Square hole, 42x15	0.3	Not included
180005735	PMC-DCT-800A-4V-A	800(1200)A	Class 1	Square hole, 64x16	0.3	Not included
180008434	PMC-DCT-1000A-4V-A	1000(1500)A	Class 1	Square hole, 104x36	0.3	Not included
180008435	PMC-DCT-2000A-4V-A	2000(3000)A	Class 1	Square hole, 104x36	0.3	Not included

The cables for connecting PMC-D961MD to Hall-Effect Sensors are not included. The recommended wire size is 0.5 - 1.0 mm<sup>2</sup>.

## Standards of Compliance

Safety Requirements	
CE LVD 2014 / 35 / EU	EN 61010-1: 2010 + A1: 2019 EN IEC 61010-2-030: 2021 + A11: 2021
Electrical Safety in Low Voltage Distribution Systems up to 1000Vac and 1500 Vdc	IEC 61557-12: 2021 (PMD)
Insulation	IEC 62052-31: 2015 EN 61010-1: 2010 + A1: 2019
Dielectric test: Insulation resistance: Impulse voltage:	1.5kV @ 1 minute >100MΩ 6kV, 1.2/50μs
Electromagnetic Compatibility CE EMC Directive 2014 / 30 / EU (EN IEC 61326: 2021)	
Immunity Tests	
Electrostatic Discharge	EN 61000-4-2: 2009
Radiated Fields	EN 61000-4-3: 2020
Fast Transients	EN 61000-4-4: 2019
Surges	EN 61000-4-5: 2014 + A1: 2017
Conducted Disturbances	EN 61000-4-6: 2014 + AC: 2015
Magnetic Fields	EN 61000-4-8: 2010
Voltage Dips and Interruptions	EN IEC 61000-4-11: 2020
Ring Wave	EN 61000-4-12: 2017
Immunity Standard for Industrial Environments	EN IEC 61000-6-2: 2019
Emission Tests	
Limits and Methods of Measurement of Electromagnetic Disturbance Characteristics of Industrial, Scientific and Medical (ISM) Radio-Frequency Equipment	EN 55011: 2016 + A1: 2017 + A11: 2020 + A2: 2021
Electromagnetic Compatibility of Multimedia Equipment - Emission Requirements	EN 55032: 2015 + AC: 2016 + A11: 2020 + A1: 2020
Limits for Harmonic Current Emissions for Equipment with Rated Current ≤16 A	EN IEC 61000-3-2: 2019 +A1: 2021
Limitation of Voltage Fluctuations and Flicker in Low-Voltage Supply Systems for Equipment with Rated Current ≤16 A	EN 61000-3-3: 2013 + A1: 2019 + A2: 2021
Emission Standard for Industrial Environments	EN IEC 61000-6-4: 2019
Mechanical Tests	
Spring Hammer Test	IEC 62052-31: 2015
Shock Test	IEC 62052-11: 2020
Vibration Test	IEC 62052-11: 2020

## CET Electric Technology Inc.

E: [sales@cet-global.com](mailto:sales@cet-global.com)

W: [www.cet-global.com](http://www.cet-global.com)

## Your Local Representative

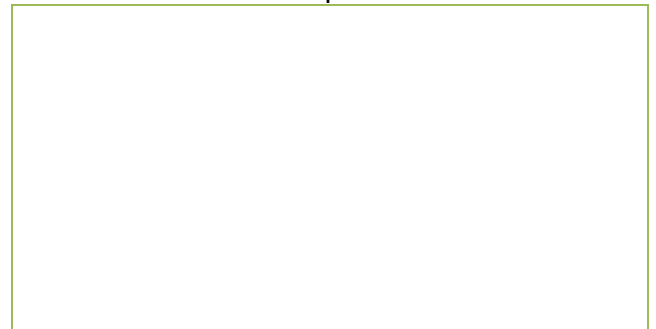

Revision Date: March 25, 2026

Designed For Reliability

Manufactured To Last